



Doosan Infracore
Construction Equipment

DX140W

Engine Power : SAE J1349, net 99 kW(132HP)@2,000rpm

Operational Weight : 13,750 ~ 15,560 kg (30,313 ~ 34,292 lb)

Bucket capacity(SAE) : 0.24 ~ 0.76 m³ (0.31 ~ 0.99 cu.yd)



Photo may include optional equipment



DX 140W



The new DX140W hydraulic excavator has all the advantages of the previous model, and now offers additional added value to the operator.

The new DX140W was developed with the concept of “providing optimum value to the end user.” In concrete terms, this translates, into :



Doosan DX140W Hydraulic Excavator : A New Model with Novel Features

Increased production and improved fuel economy is attributed to the electronic optimization of the hydraulic system and the new generation DOOSAN engine (Tier 4 / Stage II).

Improved ergonomics increases comfort and excellent all round visibility ensuring a safe and pleasant working environment.

Improved reliability is achieved through the use of high performance materials combined with new methods of structural stress analysis, and leads to increased component life expectancy, thus reducing running costs.

Reduced maintenance increases the availability and reduces operating costs of the excavator.

HANDLING

The hydraulic excavator's power, durability, ease of servicing and its precise control increase its effectiveness and life expectancy. With the DX140W, DOOSAN offers an excellent return on investment.



Multi-function Color LCD Monitor Panel

Warning lights

Operation modes

- Mode selection
- Flow rate control
- Auto deceleration
- Display selection

Control panel

With color LCD display

Choice of operating modes

Working mode

- Digging mode: for general excavation, loading, lifting...
- Trenching mode: swing priority for trench work, canal digging, embankments...

Power mode

- Standard: uses 85% engine power for all work
- Power: uses 100% engine power for heavy work



Control lever

Very precise control of the equipment increases versatility, safety and facilitates tricky operations requiring great precision.

Leveling operations and particularly the movement of suspended loads are made easier and safer.

The control levers have additional electrical buttons for controlling other additional equipment (for example, grabs, crushers, grippers, etc.)

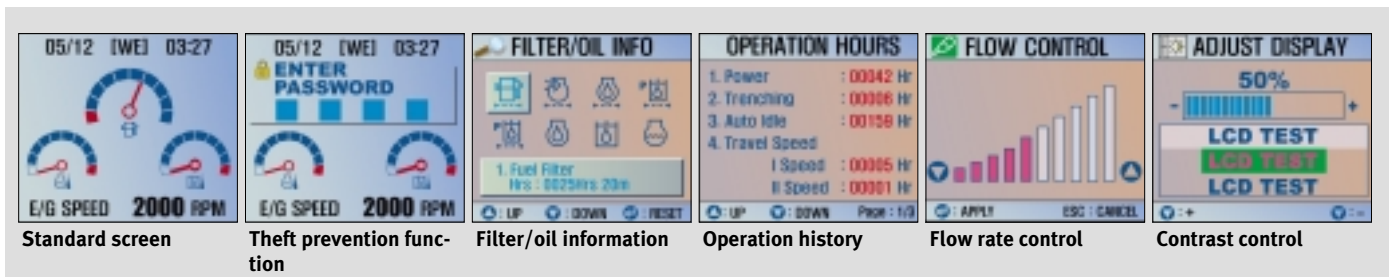

Standard screen

Theft prevention function

Filter/oil information

Operation history

Flow rate control

Contrast control



Cellular phone box



12V Power socket/Cigarette lighter



Glass antenna



Storage space

COMFORT

DX140W

The work rate of the hydraulic excavator is directly linked to the performance of its operator. DOOSAN designed the DX140W by putting the operator at the centre of the development goals. The result is significant ergonomic value that improves the efficiency and safety of the operator.

More space, better visibility, air conditioning, a very comfortable seat... These are all elements that ensure that the operator can work for hours and hours in excellent conditions.



Control panel
Correct positioning with clear controls makes the operator's task easier.

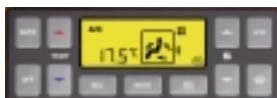

Rear Camera



MP3/CD Player (Optional)

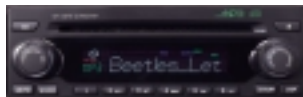

Audio Button

Audio Button has been positioned in a way that the driver can turn on/off the radio, control the volume, and select a channel conveniently.



The high performance air conditioning provides an air flow which is adjusted and electronically controlled for the conditions. Five operating modes enable even the most demanding operator to be satisfied.



Steering wheel



Steering Column

The Forward/Neutral/Reverse & gear selection switch is mounted on the steering column to minimize operator movements while traveling so that safety and operator comfort are ensured. The lower part of Steering Column can be tilted for improved operator comfort.



Air suspension seat (Optional)
An Air Suspension Seat is available as an option, which further reduces any vibration being transmitted to the operator while working or travelling. In addition, this option is fitted with a heating system for operator comfort in cold weather.



Dozer/Outrigger Control
The Dozer/Outrigger Control Lever, combined with the associated switches, allows for the operator to select between any combination of independent or simultaneous operation of the dozer/Outriggers.



Foot Pedals
The position of the Option, Brake and Accelerator Pedal have been set by ergonomic analysis to maximise operating efficiency while minimizing foot movement. The required pedal operating forces have also been decreased to reduce fatigue.



Comfortable 2-stage sliding seat

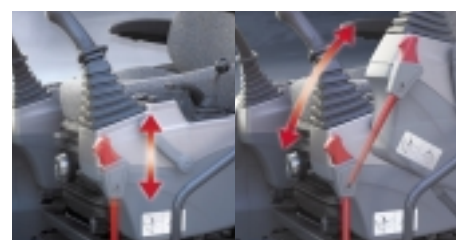

Control stand (Telescopic & Tilting Function)

PERFORMANCE

The performance of the DX140W has a direct effect on its productivity. Its new e-EPOS controlled hydraulic system have combined to create an unbeatable hydraulic excavator, with a cost/performance ratio that makes the DX140W even more appealing.

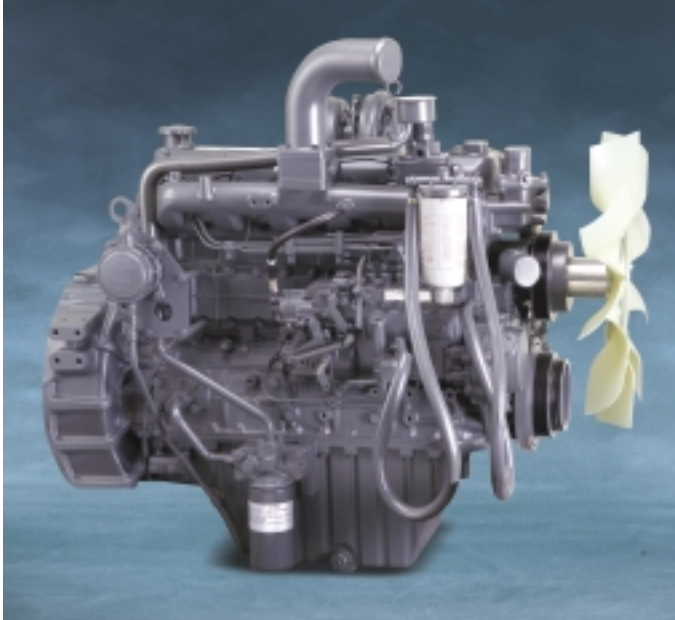

DOOSAN DB58TIS ENGINE

At the heart of the hydraulic excavator is the new DOOSAN DB58TIS engine. It is combined with the new e-EPOS electronic control system, for optimum power and fuel saving.

The new engine produces 132 hp(99 kw/134 PS) at only 2,000 rpm.

Increased torque allows efficient use of the power of the hydraulic system.

- Faster working cycles increase productivity.
- Increased torque means the excavator is able to move more easily.
- Energy efficiency reduces fuel consumption.



Hydraulic Pump

Considering the property of wheel excavator that intensively performs traveling operation, bent axis piston pump is adopted for its high efficiency and excellent response in high pressure. The Main pump has a capacity of 2x156.1 /min(@ 2,000rpm) reducing cycle time while a high capacity gear pump improves pilot line efficiency.

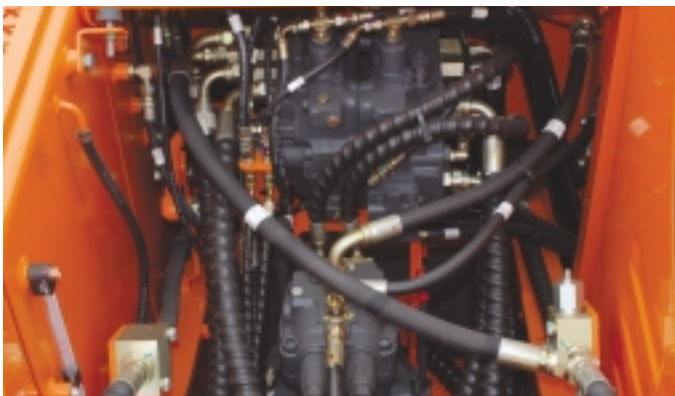

Swing drive

Shocks during rotation are minimized, while increased torque is available to ensure rapid cycles.

EXCAVATOR CONTROL

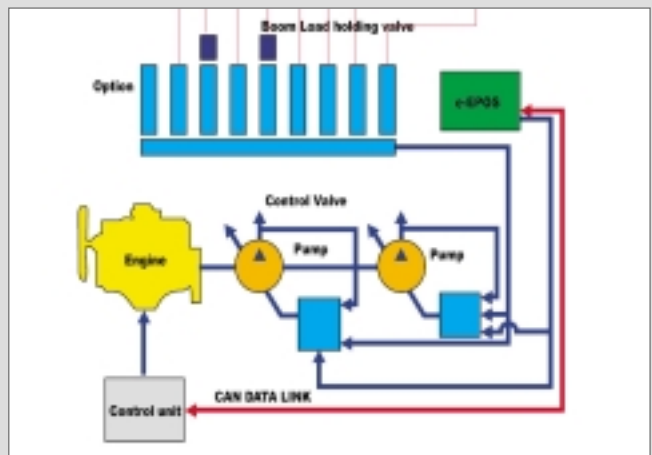

New e-EPOS system (Electronic Power Optimizing System)

The brains of the hydraulic excavator, the e-EPOS, have been improved and now can electronically link to the engines ECU (Electronic Control Unit), through a CAN (Controller Area Network) communication link, enabling a continuous exchange of information between the engine and the hydraulic system. These units are now perfectly synchronised.

The advantages of the new e-EPOS impacts at several levels, Ease of operation and user-friendliness:

- The availability of a power mode and a normal operating mode guarantee maximum efficiency under all conditions.
- Electronic control of fuel consumption optimizes efficiency.
- The automatic deceleration mode enables fuel saving.
- Regulation and precise control of the flow rate required by the equipment are available as standard.
- A self-diagnosis function enables technical problems to be resolved quickly and efficiently.
- An operational memory provides a graphic display of the status of the machine.
- Maintenance and oil change intervals can be displayed.



New Drive Line Concept

The new travel motor and transmission control in the drive line provide comfortable travel due to increased smoothness, improved hydraulic retarding and improved gear shifting.

Heavy Duty Axles

The front axle offers wide oscillating and steering angles. The transmission is mounted directly on the rear axle for protection and optimum ground clearance.

Advanced Disc Brake System

The new disc brake system works directly on the hub instead of the drive shaft to avoid planetary gear backlash. This eliminates the rocking effect associated with working free on wheels. The new axle is designed for low maintenance and the oil change intervals have been increased from 1,000 to 2,000 hours further reducing owning and operating costs.



Undercarriage Design

A rigid, welded frame provides excellent durability. Efficient hydraulic lines routing, transmission protection and heavy duty axles make the undercarriage perfect for wheel excavator applications.

Both outriggers and dozer blade are pin type for maximum flexibility. An optional work tool restraint bar is available.

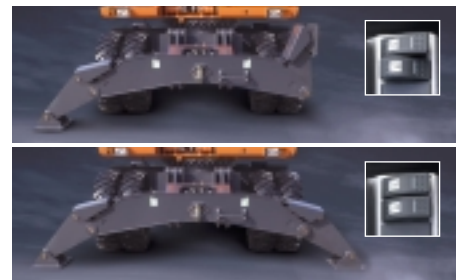

Outriggers

The pin type design allows the outriggers to be mounted on the front and/or rear for maximum operating stability when digging or lifting and are individually controlled for leveling on slopes.

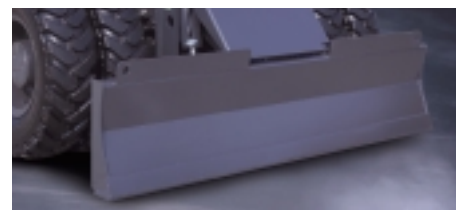

Dozer Blade

The pin type design allows the dozer blade to be mounted on the front and/or rear and is used for leveling, clean-up work and for stabilizing the machine during digging applications. The large dozer bottom and parallel design provide minimized ground pressure.

RELIABILITY

The reliability of an item of plant contributes to its overall lifetime operating costs. DOOSAN uses computer-assisted design techniques, highly durable materials and structures then test these under extreme conditions.

Durability of materials and longevity of structures are our first priorities.

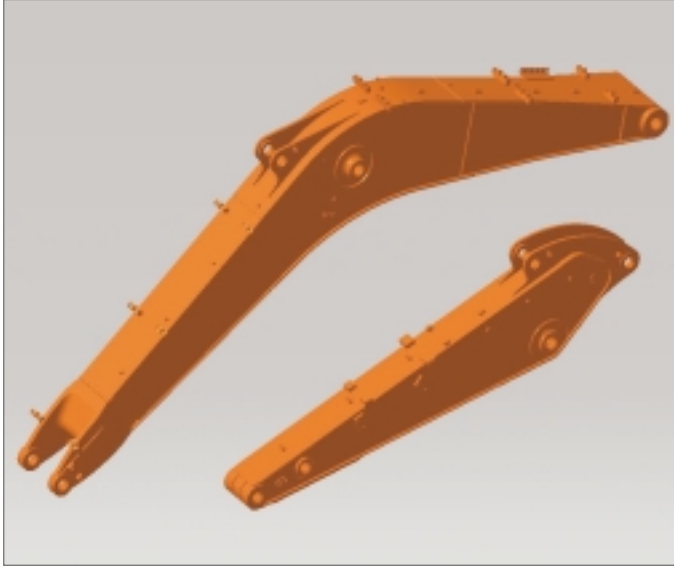

Strengthened Boom

The shape of the boom has been optimized by finite elements design, allowing uniform load distribution throughout the structure. This combined with increased material thickness means improved durability and reliability by limiting element fatigue.

Arm Assembly

In the arm assembly greater strength has been gained by using cast elements and reinforcement around the bosses to give increased life.

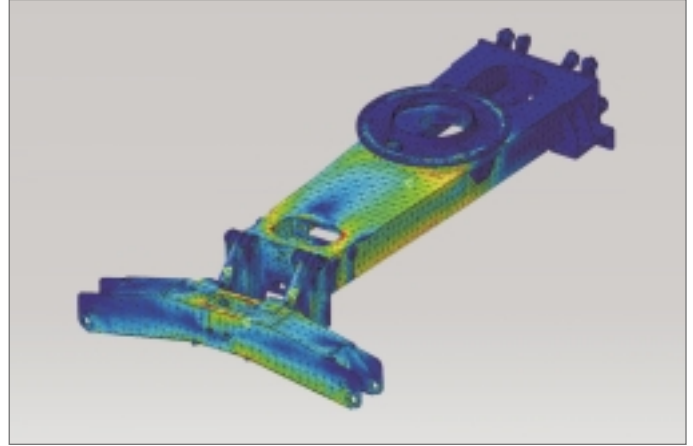

Stress Analysis Design (FEM) and Innovative Manufacturing Technique Provides a Strong and Stable Undercarriage

The Chassis Frame, Outrigger Assembly and Dozer Blade have been designed by interpretative techniques and reliability testing using 3 dimension CAD tools, to ensure improved durability and reliability.

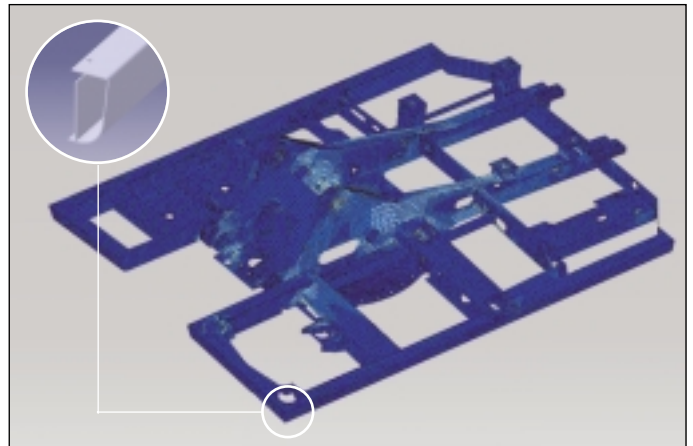

D-type Frame

The D-type frame design adds strength and minimizes distortion due to shocks.

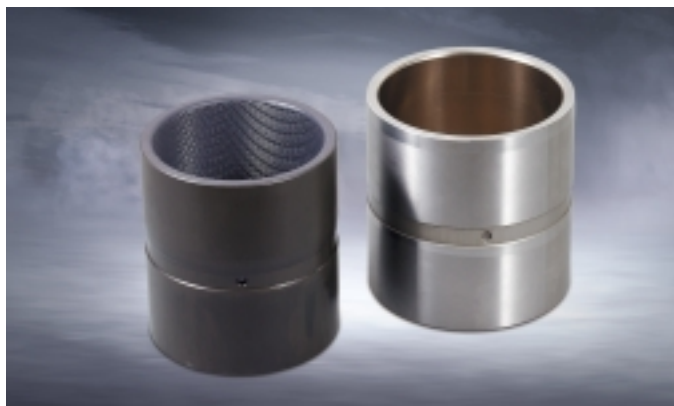

Bushing

A highly lubricated metal is used for the boom pivot in order to increase the life-time and extend the greasing intervals to 250 hours. A rolled bushing, with very fine grooves, has been added to the arm, bucket, dozer, and outrigger pivot; so greasing is only required every 50 hours.



Polymer shim

A polymer shim is added to the bucket, dozer, and outrigger pivot to promote extended pin and bushing life.



Dozer & Outrigger Cylinders Protection Covers
Large reinforced protective covers have been adopted to completely protect the Dozer & Outrigger cylinders from falling stones etc, while the machine is operating.



Cast Counterweight
A Cast Counterweight has been adopted to minimize deformation by external impact. In addition, operating stability has been increased by use of a low center of gravity design.



LED (luminescent diode) Type Stop Lamps
The use of LED type Stop Lamps ensures considerably improved average service life compared to the existing standard filament bulbs. Furthermore, the faster lighting speed helps contribute to accident prevention.

MAINTENANCE

Short maintenance operations at long intervals increase the availability of the equipment on site. DOOSAN has developed the DX140W with a view to high profitability for the user.



Engine oil filter

Filtering even the foreign particles and maintaining low difference in pressure, it elongates the life of engine. The installation position was specifically selected for easy access so that filter can be replaced without staining surroundings.

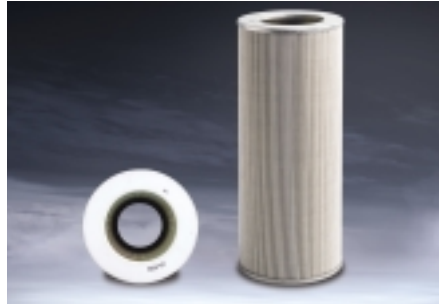

Return filter for hydraulic fluid

Eliminating 99.5% of the foreign substances in the hydraulic fluid, the high efficiency/ high capacity return filter produced of glass fiber media protects the high priced hydraulic equipment and considerably lengthens the replacement interval.

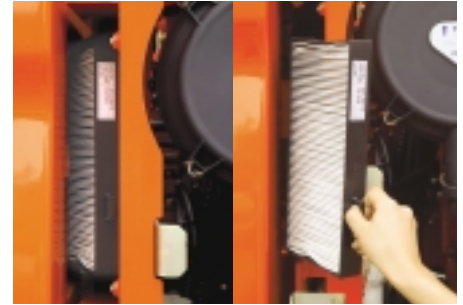

Air-conditioner filter

Since independent air-conditioner filter for internal and external machine, fresh air is supplied indoors.

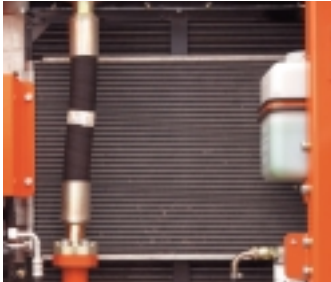

Radiator and oil cooler

Radiator and oil cooler in high capacity and high efficiency are attached so that the best cooling function can be maintained all the time.



Water separator

As water separator in high capacity and high efficiency are applied, water does not penetrate into engine.

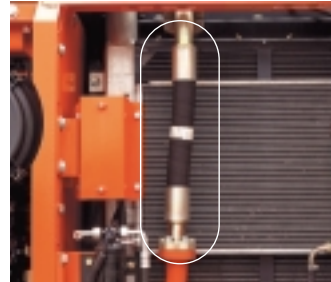

Applying stainless tube

Stainless tube is applied to oil cooler piping to prevent oil leakage.

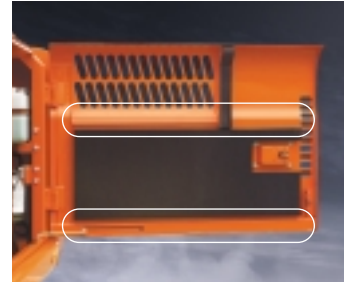

Solid side door

The muscular appearance and internal reinforced board in attachment type realize both good appearance and solid strength.



Air cleaner

The life of engine is elongated by air cleaner with the largest capacity in the same grade, easy serviceability and distinguished dust elimination effect over 99%.

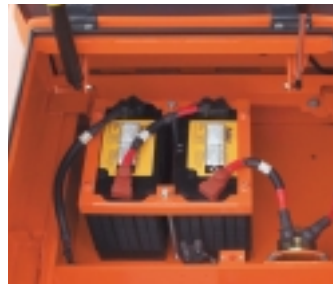

Battery cover

As battery cover is applied, shortage is prevented and customer is protected from unexpected accident.

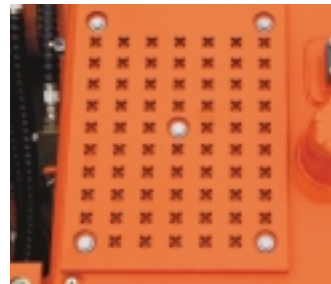

Punching cover in asterisk shape

As anti-skid cover punched in asterisk shape is added on the upper part, slippery is prevented for service to increase safety.



Fuel tank in high capacity

Thanks to the fuel tank with the maximum capacity of 280 liter in the same grade, consecutive work time is elongated.

Remarkable elongation of consumables replacement

Very economic thanks to remarkable elongation of consumables replacement

- Engine oil, engine oil filter 500 hours
- Return filter 1,000 hours
- Hydraulic fluid 2,000 hours
- Air cleaner 2,000 hours

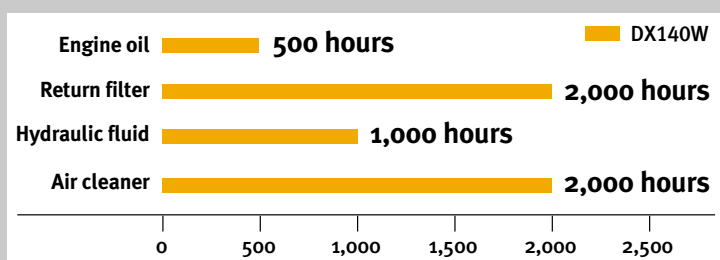

* The replacement interval depends on oil grade.

DX140W



* ENGINE

• Model	DOOSAN DB58TIS (Tier2)
• Number of cylinders	6
• Nominal flywheel power	99 kW(132HP) @ 2,000 rpm (SAE J1349, net)
• Max torque	50 kgf.m(490 Nm) at 1,400 rpm
• Piston displacement	5,890 cc (359 cu.in)
• Bore & stroke	100 mm x 125 mm (3.9" X 4.9")
• Starter	24 V / 4.5 kW
• Batteries	2 x 12 V / 100 Ah
• Air cleaner	Double element with auto dust evacuation.

* HYDRAULIC SYSTEM

The heart of the system is the e-EPOS (Electronic Power Optimizing System). It allows the efficiency of the system to be optimized for all working conditions and minimizes fuel consumption.

The new e-EPOS is connected to the engine electronic control via a data transfer link to harmonize the operation of the engine and hydraulics.

- The hydraulic system enables independent or combined operations.
- Cross-sensing pump system for fuel savings.
- Auto deceleration system.
- Two operating modes, two power modes.
- Button control of flow in auxiliary equipment circuits.
- Computer-aided pump power control.

• Main pumps

2 variable displacement axial piston pumps
max flow: 2 x 156.1 /min (2 X 41.2US gpm, 2 X 34.3 lmp gpm)

• Pilot pump

Gear pump - max flow: 18.5 /min (4.9US gpm, 4.1 lmp gpm)

• Maximum system pressure

Boom/Arm/Bucket:

- Normal mode: 330 kgf/cm²(324 bar)

- Power mode: 350 kgf/cm²(343 bar)

Travel: 350 kgf/cm²(343 bar)

Swing: 245 kgf/cm²(240 bar)

* WEIGHT

Operating weight, including 4,300 mm (14'1") one-piece boom, 2,100mm (6'11")arm, operator, lubricant, coolant, full fuel tank and the standard equipment. Weights are with 439kg (968 lb) bucket.

Undercarriage type		Operating weight (One-piece Boom)
Front attach	Rear attach	
Cradle	Dozer	13,750 kg (30,313 lb)
Cradle	Outrigger	14,078 kg (31,036 lb)
Dozer	Outrigger	14,658 kg (32,315 lb)
Outrigger	Dozer	14,685 kg (32,374 lb)
Outrigger	Outrigger	15,013 kg (33,098 lb)

* HYDRAULIC CYLINDERS

The piston rods and cylinder bodies are made of high-strength steel. A shock absorbing mechanism is fitted in all cylinders to ensure shock-free operation and extend piston life.

[One-piece Boom]

Cylinders	Quantity	Bore x Rod diameter x stroke
Boom	2	110 X 75 X 1,048mm(4.3" X 2.9" X 3'5")
Arm(short)	1	115 X 80 X 1,075mm(4.5" X 3.1" X 3'6")
Bucket	1	95 X 65 X 900mm(3.7" X 2.6" X 2'11")

* UNDERCARRIAGE

Heavy-duty frame, all-welded stress-relieve structure. Top grade materials used for toughness. Specially heat-treated connecting pins. 10.00-20-14PR double tires with tire spacer. Front axle oscillating hydraulically.

Rear dozer as a standard or outrigger as an option.

Dozer and outrigger can be installed in front and rear interchangeably.

18-19.5 20 PR tubeless single and 10.0-20 16 PR double tires as an option.

* ENVIRONMENT

Noise levels comply with environmental regulations (dynamic values).

• LWA External sound level

101 dB(A) (2000/14/EC)

• LPA Operator sound level

74 dB(A) (ISO 6396)

* BUCKET

Capacity		Width		Weight	Recommendation			
					4,300mm (14'1") One-piece Boom		4,600mm (15'1") One-piece Boom	
PCSA, heaped	CECE heaped	Without side cutters	With side cutters		2,100mm (6'11")Arm	2,100mm (6'11")Arm	2,500mm (8'2")Arm	3,000mm* (9'8")Arm
0.24m ³ (0.31yd ³)	0.22m ³	468.4mm (1'6")	534mm (1'9")	294 kg (648 lb)	A	A	A	A
0.39m ³ (0.51yd ³)	0.35m ³	736.4mm (2'5")	819.8mm (2'8")	362 kg (798 lb)	A	A	B	A
0.45m ³ (0.59yd ³)	0.40m ³	823.8mm (2'8")	911mm (3')	402 kg (886 lb)	A	B	B	A
0.51m ³ (0.67yd ³)	0.45m ³	907.4mm (3')	991mm (3'3")	418 kg (922 lb)	B	B	C	B
0.59m ³ (0.77yd ³)	0.51m ³	997.4mm (3'3")	1,081mm (3'7")	439 kg (968 lb)	B	C	C	C
0.64m ³ (0.83yd ³)	0.55m ³	1,083.4mm (3'7")	1,167mm (3'10")	465kg (1,025 lb)	C	C	-	C
0.76m ³ (0.99yd ³)	0.65m ³	1,120mm (3'8")	1,220mm (4')	519 kg (1,144 lb)	C	-	-	D
0.42m ³ (HD) (0.55yd ³)	0.38m ³	762mm (2'6")	827mm (2'9")	442 kg (974 lb)	B	C	C	A
0.49m ³ (HD) (0.64yd ³)	0.44m ³	848mm (2'9")	913mm (3')	477 kg (1,052 lb)	C	C	-	B
0.54m ³ (HD) (0.70yd ³)	0.48m ³	916mm (3')	981mm (3'3")	497 kg (1,096 lb)	C	-	-	C

A. Suitable for materials with density of 2,000 kg/m³ (3,370 lb/cu • yd) or less
 B. Suitable for materials with density of 1,600 kg/m³ (2,700 lb/cu • yd) or less
 C. Suitable for materials with density of 1,100 kg/m³ (1,850 lb/cu • yd) or less

* SWING MECHANISM

- An axial piston motor with two-stage planetary reduction gear is used for the swing.
- Increased swing torque reduces swing time.
- Internal induction-hardened gear.
- Internal gear and pinion immersed in lubricant bath.
- The swing brake for parking is activated by spring and released hydraulically.

Swing speed: 0 to 11.3 rpm

* DRIVE

Fully hydrostatic driven, 3 speed power shift transmission, variable displacement, high torque, axial piston motor, foot pedal controls provide smooth travel, hub reduction type front steering axle and rear rigid axle.

• Travel speed (High)

37 km/h (23 mph)

• Maximum traction force

7,700 kgf (16,975 lbf)

• Maximum grade

35° / 70%

* REFILL CAPACITIES

• Fuel tank

280 (74 US gal, 61.6 Imp gal)

• Cooling system (Radiator capacity)

20 (5.3 US gal, 4.4 Imp gal)

• Engine oil

22 (5.8 US gal, 4.8 Imp gal)

• Swing drive

2 (0.5 US gal, 0.4 Imp gal)

• Power train(each)

Front Axle 2.5 (0.66 US gal, 0.55 Imp gal)

Rear Axle 2.4 (0.63 US gal, 0.53 Imp gal)

Transmission 2.5 (0.66 US gal, 0.55 Imp gal)

• Hydraulic system

155 (40.9 US gal, 34.1 Imp gal)

• Hydraulic tank

102 (26.9 US gal, 22.4 Imp gal)

* 3,000mm arm should be equipped with 2,500kg C/W

DIMENSIONS

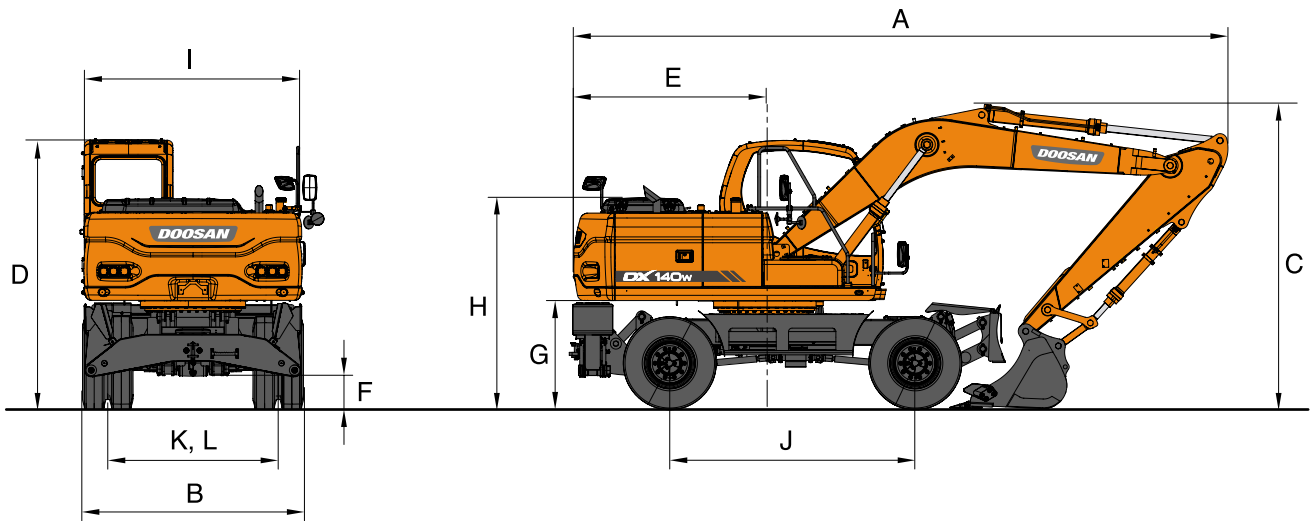

Boom type (One-piece)	4,300mm (14'1")	4,600mm (15'1")		
Arm type	2,100mm (6'11")	2,100mm (6'11")	2,500mm (8'2")	3,000mm (9'8")
A Shipping Length	7,235mm (23'9")	7,820mm (25'8")	7,470mm (24'6")	7,820mm (25'6")
B Shipping Width	2,496mm (8'2")			
C Shipping Height (Boom)	3,351mm (11')	3,225mm (10'7")	3,460mm (11'4")	3,650mm (11'9")
D Height Over Cab.	3,040mm (10')			
E Counter Weight Swing Clearance	2,200mm (7'3")			
F Ground Clearance	350mm (1'2")			
G Counter Weight Clearance	1,206mm (4')			
H Engine Cover Height	2,376mm (7'10")			
I Upper Housing Width	2,494mm (8'2")			
J Wheel Base	2,800mm (9'2")			
K, L Tread Width	1,944mm (6'5")			

* DIGGING FORCE (ISO)

Bucket (PCSA)	0.24m ³	0.39m ³	0.45m ³	0.51m ³	0.59m ³	0.64m ³	0.76m ³	0.42m ³ (HD)	0.49m ³ (HD)	0.54m ³ (HD)
Digging force	10,140 kgf	10,140 kgf	10,140 kgf	10,140 kgf	10,140 kgf	10,140 kgf	10,140 kgf	10,140 kgf	10,140 kgf	10,140 kgf
	99.5 kN	99.5 kN	99.5 kN	99.5 kN	99.5 kN	99.5 kN	99.5 kN	99.5 kN	99.5 kN	99.5 kN
	22,355 lbf	22,355 lbf	22,355 lbf	22,355 lbf	22,355 lbf	22,355 lbf	22,355 lbf	22,355 lbf	22,355 lbf	22,355 lbf
Arm	2,100mm			2,500mm			3,000mm			
Digging force	7,650 kgf			6,550 kgf			5,955 kgf			
	75.02 kN			64.23 kN			58.4 kN			
	16,865 lbf			14,440 lbf			13,129 lbf			

At power boost (ISO)

WORKING RANGES

DX140W

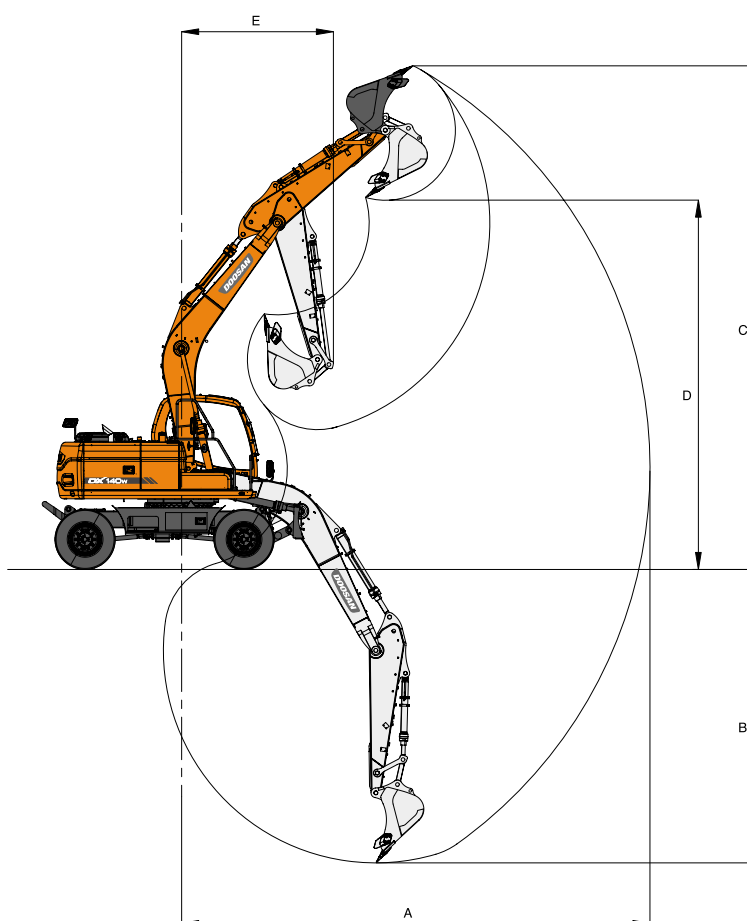

* WORKING RANGE

Boom type (One-piece)	4,300mm (14'1")		4,600mm (15'1")	
Arm type	2,100mm (6'11")	2,100mm (6'11")	2,500mm (8'2")	3,000mm (9'8")
A Max. Digging Reach	7,520mm (24'8")	7,790mm (25'7")	8,250mm (27'1")	8,647mm (28'4")
B Max. Digging Depth	4,580mm (15')	4,790mm (15'9")	5,190mm (17')	5,590mm (18'4")
C Max. Digging Height	8,130mm (26'8")	8,370mm (27'6")	8,850mm (29')	8,969mm (29'4")
D Max. Dump Height	5,810mm (19'1")	6,060mm (19'11")	6,480mm (21'3")	6,711mm (22')
E Min. Swing Radius	2,470mm (8'1")	2,570mm (8'5")	2,670mm (8'9")	2,880mm (9'4")

Undercarriage

DX 140W

*** Undercarriage with front cradle and rear outrigger / front cradle and rear dozer**

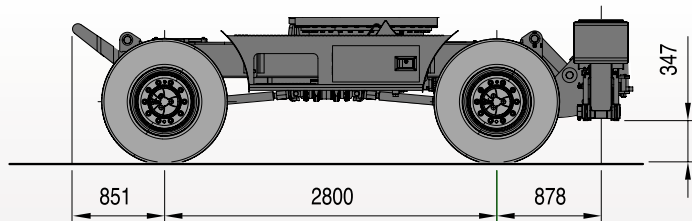

Front Cradle and Rear outrigger

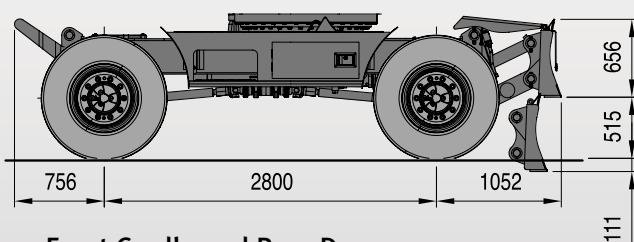

Front Cradle and Rear Dozer

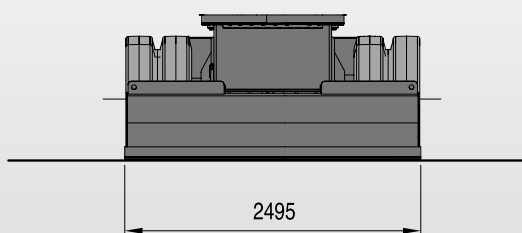

*** Undercarriage with front outrigger and rear dozer**

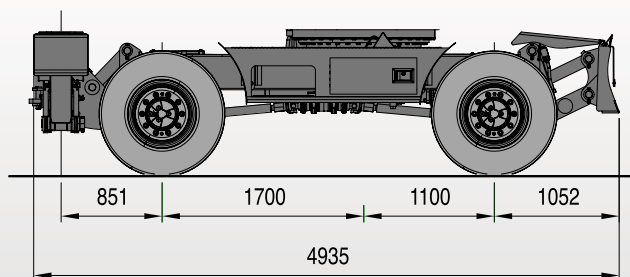
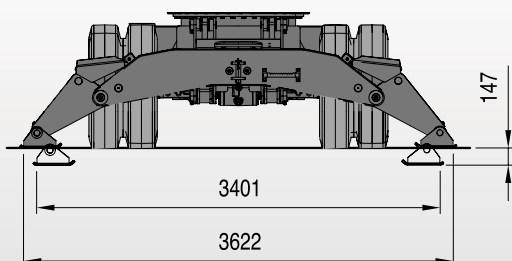

*** Undercarriage with front outrigger and rear outrigger / front dozer and rear outrigger**

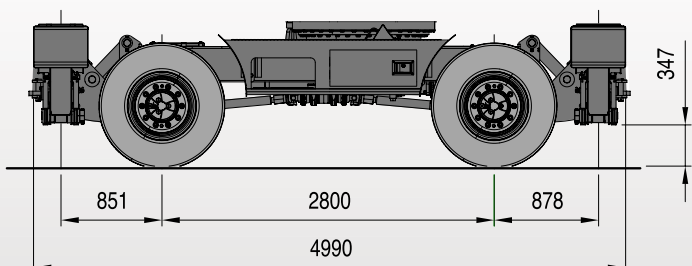

Front Outrigger and Rear Outrigger

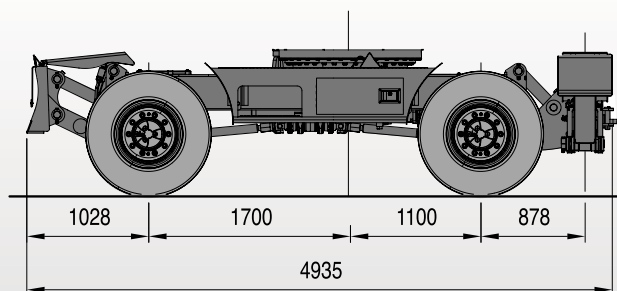

Front Dozer and Rear Outrigger

STANDARD AND OPTIONAL EQUIPMENT

* STANDARD EQUIPMENT

• Hydraulic system

- Boom and arm flow regeneration
- Boom and arm holding valves
- Swing anti-rebound valves
- Spare ports(valve)
- One-touch power boost

• Cabin & Interior

- Viscous cab mounts
- All weather sound suppressed type cab
- Air conditioner
- Adjustable suspension seat with head rest and adjustable arm rest
- Pull-up type front window and removable lower front window
- Room light
- Intermittent windshield wiper
- Cigarette lighter and ashtray
- Cup holder
- Hot & Cool box
- LCD color monitor panel
- Engine speed (RPM) control dial
- AM/FM radio and cassette player
- Remote radio ON/OFF switch
- 12V spare powers socket
- Serial communication port for laptop PC interface
- Joystick lever with 3 switches
- Sunvisor
- Sun roof
- Wiper

• Safety

- Large handrails and step
- Punched metal anti-slip plates
- Seat belt
- Hydraulic safety lock lever
- Safety glass
- Hammer for emergency escape
- Right and left rearview mirrors
- Reverse travel alarm
- Emergency engine stop
- LED stop lamps

• Others

- Double element air cleaner
- Dust screen for radiator/oil cooler/Charged Air Cooler
- Engine overheat prevention system
- Engine restart prevention system
- Self-diagnostic system
- Alternator(24V, 60 amps)
- Electric horn
- Halogen working lights(frame mounted 2, boom mounted 2)
- Double fuel filter
- 1.8ton Cast Counterweight

• Undercarriage

- 10.00-20 14PR double tires
- Heavy duty axles
- Parallel dozer blade
- Tool box
- 4 Speed(creep, low, econo, high)
- Front axle oscillation cyl. auto Lock

* OPTIONAL EQUIPMENT

Some of these optional equipment may be standard in some markets. Some of these optional equipment cannot be available on some markets. You must check with the local DOOSAN dealer to know about the availability or to release the adaptation following the needs of the applications.

• Safety

- Boom and arm hose rupture protection valve
- Overload warning device
- Cabin Top/Front guard(ISO 10262, FOGS standard)
- Rotation beacon
- Mirror & Lamp on counterweight

• Cabin & Interior

- Air suspension seat
- MP3/CD player
- 2 Front lamps
- 4 front + 2 rear lamps
- Rain shield

• Others

- Piping for crusher
- Piping for quick clamp
- Piping for front attachment rotation
- Lower wiper
- Fuel heater
- Large capacity alternator (24v, 80 amps)
- Fuel filler pump

• Undercarriage

- Front Cradle
- Dozer blade
- Outriggers
- Individually controlled outriggers
- 10.00-20 16 PR double tires
- 18-19.5 20 PR single tire
- 2.5ton cast counterweight
- 2.2ton Cast Counterweight

LIFTING CAPACITY

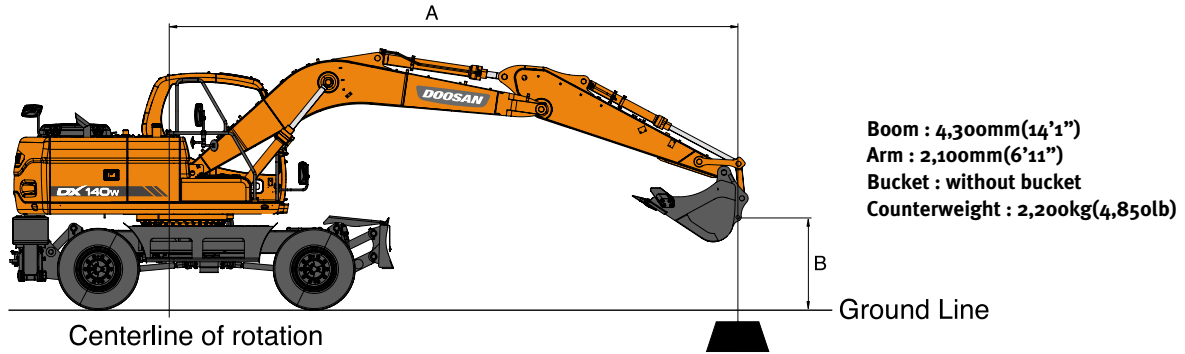

Metric

Unit : 1,000kg

A(m)	B(m)	Chassis Frame Attachment	3		4		5		6		Max. Reach		A(m)
6		R-Rear Dozer Only Up			*4.43	4.24					*2.97	*2.97	4.59
		R-Rear Dozer Only Down			*4.43	*4.43					*2.97	*2.97	
		R-Outrigger Only Down			*4.43	*4.43					*2.97	*2.97	
		F-Dozer + R-Outrigger Down			*4.43	*4.43					*2.97	*2.97	
5		R-Rear Dozer Only Up			*5.26	4.22	*4.18	3.02			*2.87	2.72	5.36
		R-Rear Dozer Only Down			*5.26	*5.26	*4.18	3.97			*2.87	*2.87	
		R-Outrigger Only Down			*5.26	*5.26	*4.18	*4.18			*2.87	*2.87	
		F-Dozer + R-Outrigger Down			*5.26	*5.26	*4.18	*4.18			*2.87	*2.87	
4		R-Rear Dozer Only Up	*7.12	6.42	*6.10	4.15	*5.51	2.99			*2.87	2.37	5.86
		R-Rear Dozer Only Down	*7.12	*7.12	*6.10	5.55	*5.51	3.94			*2.87	*2.87	
		R-Outrigger Only Down	*7.12	*7.12	*6.10	*6.10	*5.51	*5.51			*2.87	*2.87	
		F-Dozer + R-Outrigger Down	*7.12	*7.12	*6.10	*6.10	*5.51	*5.51			*2.87	*2.87	
3		R-Rear Dozer Only Up	*9.01	6.16	*6.96	4.03	5.85	2.94	*3.91	2.27	*2.96	2.19	6.15
		R-Rear Dozer Only Down	*9.01	8.69	*6.96	5.43	5.85	3.88	*3.91	2.97	*2.96	2.86	
		R-Outrigger Only Down	*9.01	*9.01	*6.96	*6.96	*5.92	5.89	*3.91	*3.91	*2.96	*2.96	
		F-Dozer + R-Outrigger Down	*9.01	*9.01	*6.96	*6.96	*5.92	*5.92	*3.91	*3.91	*2.96	*2.96	
2		R-Rear Dozer Only Up			*7.82	3.92	5.78	2.88	4.36	2.24	*3.13	2.11	6.28
		R-Rear Dozer Only Down			*7.82	5.30	5.78	3.82	4.36	2.95	*3.13	2.76	
		R-Outrigger Only Down			*7.82	*7.82	6.06	5.82	4.57	4.39	*3.13	*3.13	
		F-Dozer + R-Outrigger Down			*7.82	*7.82	*6.35	6.04	*4.97	4.56	*3.13	*3.13	
1		R-Rear Dozer Only Up	*9.08	5.76	8.28	3.82	5.71	2.83	4.33	2.22	*3.40	2.11	6.24
		R-Rear Dozer Only Down	*9.08	8.21	8.28	5.20	5.71	3.76	4.33	2.92	*3.40	2.77	
		R-Outrigger Only Down	*9.08	*9.08	*8.37	8.34	6.00	5.76	4.54	4.36	*3.40	*3.40	
		F-Dozer + R-Outrigger Down	*9.08	*9.08	*8.37	*8.37	*6.64	5.98	*5.36	4.53	*3.40	*3.40	
0(Ground)		R-Rear Dozer Only Up	*10.23	5.71	8.21	3.77	5.67	2.80	*4.13	2.20	*3.84	2.19	6.03
		R-Rear Dozer Only Down	*10.23	8.16	8.21	5.14	5.67	3.73	*4.13	2.90	*3.84	2.89	
		R-Outrigger Only Down	*10.23	*10.23	*8.44	8.27	5.96	5.72	*4.13	*4.13	*3.84	*3.84	
		F-Dozer + R-Outrigger Down	*10.23	*10.23	*8.44	*8.44	*6.66	5.94	*4.13	*4.13	*3.84	*3.84	
-1		R-Rear Dozer Only Up	*10.36	5.71	*8.00	3.76	5.66	2.79			*4.57	2.39	5.63
		R-Rear Dozer Only Down	*10.36	8.16	*8.00	5.13	5.66	3.72			*4.57	3.17	
		R-Outrigger Only Down	*10.36	*10.36	*8.00	*8.00	5.95	5.71			*4.57	*4.57	
		F-Dozer + R-Outrigger Down	*10.36	*10.36	*8.00	*8.00	*6.28	5.93			*4.57	*4.57	
-2		R-Rear Dozer Only Up	*8.87	5.76	*6.93	3.79	*5.12	2.82			*5.11	2.81	5.01
		R-Rear Dozer Only Down	*8.87	8.21	*6.93	5.16	*5.12	3.75			*5.11	3.75	
		R-Outrigger Only Down	*8.87	*8.87	*6.93	*6.93	*5.12	*5.12			*5.11	*5.11	
		F-Dozer + R-Outrigger Down	*8.87	*8.87	*6.93	*6.93	*5.12	*5.12			*5.11	*5.11	
-3		R-Rear Dozer Only Up	*6.38	5.85	*4.63	3.87					*4.54	3.82	4.04
		R-Rear Dozer Only Down	*6.38	*6.38	*4.63	*4.63					*4.54	*4.54	
		R-Outrigger Only Down	*6.38	*6.38	*4.63	*4.63					*4.54	*4.54	
		F-Dozer + R-Outrigger Down	*6.38	*6.38	*4.63	*4.63					*4.54	*4.54	

Feet

Unit : 1,000lb

A(ft) B(ft)	Chassis Frame Attachment	10'		15'		20'		Max. Reach		A(ft)
20	R-Rear Dozer Only Up									
	R-Rear Dozer Only Down									
	R-Outrigger Only Down									
	F-Dozer + R-Outrigger Down									
15	R-Rear Dozer Only Up			*11.76	7.59			*6.30	5.60	18.37
	R-Rear Dozer Only Down			*11.76	10.02			*6.30	*6.30	
	R-Outrigger Only Down			*11.76	*11.76			*6.30	*6.30	
	F-Dozer + R-Outrigger Down			*11.76	*11.76			*6.30	*6.30	
10	R-Rear Dozer Only Up	*19.35	13.29	*13.81	7.36	*7.25	4.89	*6.51	4.83	20.16
	R-Rear Dozer Only Down	*19.35	18.66	*13.81	9.78	*7.25	6.41	*6.51	6.33	
	R-Outrigger Only Down	*19.35	*19.35	*13.81	*13.81	*7.25	*7.25	*6.51	*6.51	
	F-Dozer + R-Outrigger Down	*19.35	*19.35	*13.81	*13.81	*7.25	*7.25	*6.51	*6.51	
5	R-Rear Dozer Only Up	*24.32	12.53	14.63	7.10	9.35	4.81	*7.15	4.62	20.59
	R-Rear Dozer Only Down	*24.32	17.78	14.63	9.50	9.35	6.32	*7.15	6.07	
	R-Outrigger Only Down	*24.32	*24.32	15.35	14.74	9.81	9.42	*7.15	*7.15	
	F-Dozer + R-Outrigger Down	*24.32	*24.32	*15.65	15.30	*10.24	9.79	*7.15	*7.15	
0(Ground)	R-Rear Dozer Only Up	*23.70	12.28	14.43	6.94			*8.46	4.83	19.77
	R-Rear Dozer Only Down	*23.70	17.49	14.43	9.33			*8.46	6.37	
	R-Outrigger Only Down	*23.70	*23.70	15.15	14.54			*8.46	*8.46	
	F-Dozer + R-Outrigger Down	*23.70	*23.70	*16.17	15.10			*8.46	*8.46	
-5	R-Rear Dozer Only Up	*21.06	12.33	*14.39	6.94			11.34	5.68	17.51
	R-Rear Dozer Only Down	*21.06	17.55	*14.39	9.32			11.34	7.53	
	R-Outrigger Only Down	*21.06	*21.60	*14.39	*14.39			*11.44	11.42	
	F-Dozer + R-Outrigger Down	*21.06	*21.60	*14.39	*14.39			*11.44	*11.44	
-10	R-Rear Dozer Only Up	*13.55	12.60					*9.89	8.60	13.06
	R-Rear Dozer Only Down	*13.55	*13.55					*9.89	*9.89	
	R-Outrigger Only Down	*13.55	*13.55					*9.89	*9.89	
	F-Dozer + R-Outrigger Down	*13.55	*13.55					*9.89	*9.89	

1. Ratings are based on SAE J1097
2. Load point is the end of arm.
3. * Rated loads are based on hydraulic capacity.
4. Rated loads do not exceed 87% of hydraulic capacity or 75% of tipping capacity.

: Rating Over Front

: Rating Over Side or 360 degree

LIFTING CAPACITY

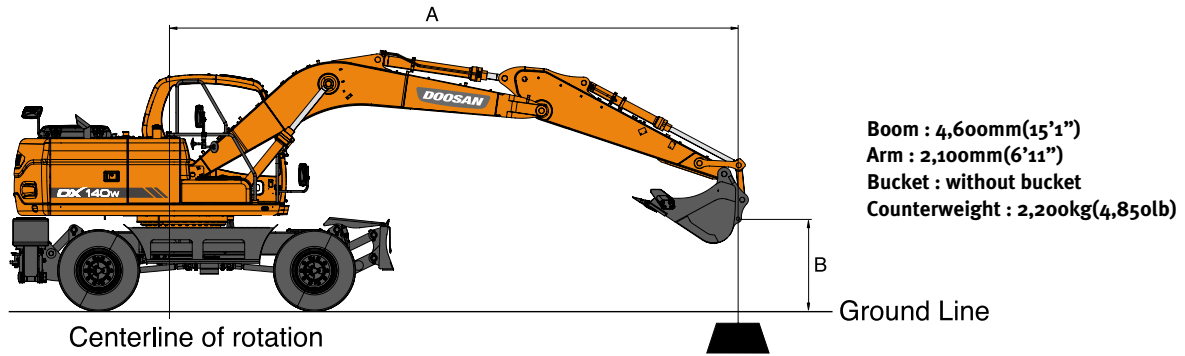

Metric

Unit : 1,000kg

A(m) B(m)	Chassis Frame Attachment	3		4		5		6		Max. Reach		A(m)
6	R-Rear Dozer Only Up			*4.86	4.25	*3.10	3.01			*2.98	*2.98	5.02
	R-Rear Dozer Only Down			*4.86	*4.86	*3.10	*3.10			*2.98	*2.98	
	R-Outrigger Only Down			*4.86	*4.86	*3.10	*3.10			*2.98	*2.98	
	F-Dozer + R-Outrigger Down			*4.86	*4.86	*3.10	*3.10			*2.98	*2.98	
5	R-Rear Dozer Only Up			*5.48	4.21	*4.93	3.02			*2.90	2.45	5.74
	R-Rear Dozer Only Down			*5.48	*5.48	*4.93	3.97			*2.90	*2.90	
	R-Outrigger Only Down			*5.48	*5.48	*4.93	*4.93			*2.90	*2.90	
	F-Dozer + R-Outrigger Down			*5.48	*5.48	*4.93	*4.93			*2.90	*2.90	
4	R-Rear Dozer Only Up	*7.45	6.36	*6.14	4.11	*5.42	2.97	*3.97	2.28	*2.90	2.16	6.20
	R-Rear Dozer Only Down	*7.45	*7.45	*6.14	5.52	*5.42	3.92	*3.97	2.98	*2.90	2.83	
	R-Outrigger Only Down	*7.45	*7.45	*6.14	*6.14	*5.42	*5.42	*3.97	*3.97	*2.90	*2.90	
	F-Dozer + R-Outrigger Down	*7.45	*7.45	*6.14	*6.14	*5.42	*5.42	*3.97	*3.97	*2.90	*2.90	
3	R-Rear Dozer Only Up			*7.03	3.98	5.82	2.91	4.37	2.25	*2.99	2.01	6.49
	R-Rear Dozer Only Down			*7.03	5.37	5.82	3.85	4.37	2.95	*2.99	2.64	
	R-Outrigger Only Down			*7.03	*7.03	*5.86	*5.86	4.59	4.41	*2.99	*2.99	
	F-Dozer + R-Outrigger Down			*7.03	*7.03	*5.86	*5.86	*5.18	4.58	*2.99	*2.99	
2	R-Rear Dozer Only Up			*7.86	3.85	5.74	2.84	4.33	2.21	*3.14	1.94	6.60
	R-Rear Dozer Only Down			*7.86	5.23	5.74	3.78	4.33	2.92	*3.14	2.55	
	R-Outrigger Only Down			*7.86	*7.86	6.02	5.78	4.55	4.37	*3.14	*3.14	
	F-Dozer + R-Outrigger Down			*7.86	*7.86	*6.30	6.00	*5.37	4.54	*3.14	*3.14	
1	R-Rear Dozer Only Up			8.20	3.75	5.67	2.78	4.29	2.18	*3.39	1.93	6.56
	R-Rear Dozer Only Down			8.20	5.12	5.67	3.71	4.29	2.88	*3.39	2.55	
	R-Outrigger Only Down			*8.33	8.26	5.95	5.71	4.51	4.33	*3.39	*3.39	
	F-Dozer + R-Outrigger Down			*8.33	*8.33	*6.58	5.93	*5.47	4.50	*3.39	*3.39	
0(Ground)	R-Rear Dozer Only Up	*7.26	5.60	8.14	3.70	5.62	2.74	4.27	2.16	*3.77	2.00	6.36
	R-Rear Dozer Only Down	*7.26	*7.26	8.14	5.07	5.62	3.68	4.27	2.86	*3.77	2.65	
	R-Outrigger Only Down	*7.26	*7.26	*8.34	8.19	5.91	5.67	4.49	*4.31	*3.77	*3.77	
	F-Dozer + R-Outrigger Down	*7.26	*7.26	*8.34	*8.34	*6.61	5.89	*5.38	4.48	*3.77	*3.77	
-1	R-Rear Dozer Only Up	*10.06	5.61	*7.90	3.69	5.61	2.73			4.28	2.17	5.99
	R-Rear Dozer Only Down	*10.06	8.06	*7.90	5.06	5.61	3.66			4.28	2.87	
	R-Outrigger Only Down	*10.06	*10.06	*7.90	*7.90	5.89	5.65			*4.40	4.32	
	F-Dozer + R-Outrigger Down	*10.06	*10.06	*7.90	*7.90	*6.28	5.88			*4.40	*4.40	
-2	R-Rear Dozer Only Up	*8.71	5.66	*6.96	3.72	*5.43	2.75			*4.74	2.50	5.41
	R-Rear Dozer Only Down	*8.71	8.11	*6.96	5.08	*5.43	3.69			*4.74	3.32	
	R-Outrigger Only Down	*8.71	*8.71	*6.96	*6.96	*5.43	*5.43			*4.74	*4.74	
	F-Dozer + R-Outrigger Down	*8.71	*8.71	*6.96	*6.96	*5.43	*5.43			*4.74	*4.74	
-3	R-Rear Dozer Only Up	*6.62	5.75	*5.21	3.78					*4.28	3.20	4.53
	R-Rear Dozer Only Down	*6.62	*6.62	*5.21	5.15					*4.28	*4.28	
	R-Outrigger Only Down	*6.62	*6.62	*5.21	*5.21					*4.28	*4.28	
	F-Dozer + R-Outrigger Down	*6.62	*6.62	*5.21	*5.21					*4.28	*4.28	

Feet

Unit : 1,000lb

A(ft) B(ft)	Chassis Frame Attachment	10'		15'		20'		Max. Reach		A(ft)
20	R-Rear Dozer Only Up			*9.14	7.64			*6.61	*6.61	16.2
	R-Rear Dozer Only Down			*9.14	*9.14			*6.61	*6.61	
	R-Outrigger Only Down			*9.14	*9.14			*6.61	*6.61	
	F-Dozer + R-Outrigger Down			*9.14	*9.14			*6.61	*6.61	
15	R-Rear Dozer Only Up			*11.93	7.55			*6.37	5.08	19.56
	R-Rear Dozer Only Down			*11.93	10			*6.37	*6.37	
	R-Outrigger Only Down			*11.93	*11.93			*6.37	*6.37	
	F-Dozer + R-Outrigger Down			*11.93	*11.93			*6.37	*6.37	
10	R-Rear Dozer Only Up			*13.78	7.28	9.41	4.85	*6.57	4.44	21.25
	R-Rear Dozer Only Down			*13.78	9.7	9.41	6.37	*6.57	5.82	
	R-Outrigger Only Down			*13.78	*13.78	9.88	9.49	*6.57	*6.57	
	F-Dozer + R-Outrigger Down			*13.78	*13.78	*10.95	9.86	*6.57	*6.57	
5	R-Rear Dozer Only Up			14.51	6.98	9.29	4.74	*7.16	4.25	21.66
	R-Rear Dozer Only Down			14.51	9.38	9.29	6.25	*7.16	5.59	
	R-Outrigger Only Down			15.23	14.62	9.75	9.36	*7.16	*7.16	
	F-Dozer + R-Outrigger Down			*15.58	15.18	*11.81	9.73	*7.16	*7.16	
0(Ground)	R-Rear Dozer Only Up	*16.79	12.05	14.30	6.81	9.20	4.67	*8.32	4.42	20.88
	R-Rear Dozer Only Down	*16.79	*16.79	14.30	9.19	9.20	6.18	*8.32	5.84	
	R-Outrigger Only Down	*16.79	*16.79	15.01	14.41	9.67	9.28	*8.32	*8.32	
	F-Dozer + R-Outrigger Down	*16.79	*16.79	*16.01	14.97	*11.62	9.65	*8.32	*8.32	
-5	R-Rear Dozer Only Up	*20.54	12.12	14.28	6.80			10.14	5.10	18.75
	R-Rear Dozer Only Down	*20.54	17.32	14.28	9.18			10.14	6.76	
	R-Outrigger Only Down	*20.54	*20.54	*14.45	14.39			10.65	10.22	
	F-Dozer + R-Outrigger Down	*20.54	*20.54	*14.45	*14.45			*10.66	10.62	
-10	R-Rear Dozer Only Up	*14.17	12.38					*9.34	7.18	14.69
	R-Rear Dozer Only Down	*14.17	*14.17					*9.34	*9.34	
	R-Outrigger Only Down	*14.17	*14.17					*9.34	*9.34	
	F-Dozer + R-Outrigger Down	*14.17	*14.17					*9.34	*9.34	

1. Ratings are based on SAE J1097
2. Load point is the end of arm.
3. * Rated loads are based on hydraulic capacity.
4. Rated loads do not exceed 87% of hydraulic capacity or 75% of tipping capacity.

: Rating Over Front

: Rating Over Side or 360 degree

LIFTING CAPACITY

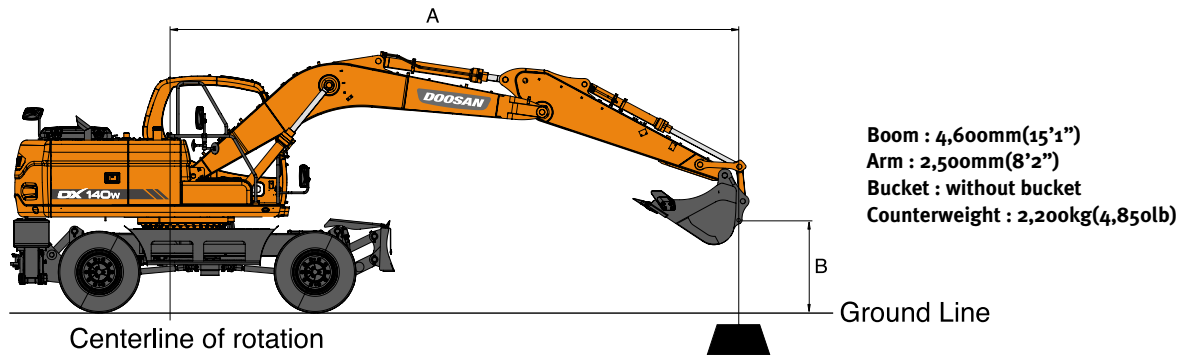

Metric

Unit : 1,000kg

A(m)	B(m)	Chassis Frame Attachment	3		4		5		6		Max. Reach		A(m)
6		R-Rear Dozer Only Up					*3.56	3.05			*2.10	*2.10	5.62
		R-Rear Dozer Only Down					*3.56	*3.56			*2.10	*2.10	
		R-Outrigger Only Down					*3.56	*3.56			*2.10	*2.10	
		F-Dozer + R-Outrigger Down					*3.56	*3.56			*2.10	*2.10	
5		R-Rear Dozer Only Up			*4.27	4.25	*4.19	3.04	*3.02	2.30	*2.02	*2.02	6.26
		R-Rear Dozer Only Down			*4.27	*4.27	*4.19	4	*3.02	3.01	*2.02	*2.02	
		R-Outrigger Only Down			*4.27	*4.27	*4.19	*4.19	*3.02	*3.02	*2.02	*2.02	
		F-Dozer + R-Outrigger Down			*4.27	*4.27	*4.19	*4.19	*3.02	*3.02	*2.02	*2.02	
4		R-Rear Dozer Only Up			*5.25	4.15	*4.93	2.99	*4.05	2.28	*2.01	1.93	6.69
		R-Rear Dozer Only Down			*5.25	*5.25	*4.93	3.94	*4.05	3	*2.01	*2.01	
		R-Outrigger Only Down			*5.25	*5.25	*4.93	*4.93	*4.05	*4.05	*2.01	*2.01	
		F-Dozer + R-Outrigger Down			*5.25	*5.25	*4.93	*4.93	*4.05	*4.05	*2.01	*2.01	
3		R-Rear Dozer Only Up	*8.55	6.14	*6.59	4.01	*5.57	2.92	4.38	2.25	*2.04	1.81	6.95
		R-Rear Dozer Only Down	*8.55	*8.55	*6.59	5.41	*5.57	3.86	4.38	2.96	*2.04	*2.04	
		R-Outrigger Only Down	*8.55	*8.55	*6.59	*6.59	*5.57	*5.57	4.60	4.41	*2.04	*2.04	
		F-Dozer + R-Outrigger Down	*8.55	*8.55	*6.59	*6.59	*5.57	*5.57	*4.92	4.58	*2.04	*2.04	
2		R-Rear Dozer Only Up			*7.52	3.86	5.74	2.84	4.33	2.20	*2.11	1.75	7.06
		R-Rear Dozer Only Down			*7.52	5.25	5.74	3.78	4.33	2.91	*2.11	*2.11	
		R-Outrigger Only Down			*7.52	*7.52	6.03	5.79	4.54	4.36	*2.11	*2.11	
		F-Dozer + R-Outrigger Down			*7.52	*7.52	*6.08	6.01	*5.22	4.53	*2.11	*2.11	
1		R-Rear Dozer Only Up			*8.15	3.75	5.66	2.77	4.28	2.16	*2.23	1.75	7.02
		R-Rear Dozer Only Down			*8.15	5.12	5.66	3.70	4.28	2.87	*2.23	*2.23	
		R-Outrigger Only Down			*8.15	*8.15	5.94	5.70	4.50	4.32	*2.23	*2.23	
		F-Dozer + R-Outrigger Down			*8.15	*8.15	*6.45	5.93	*5.40	4.49	*2.23	*2.23	
0(Ground)		R-Rear Dozer Only Up	*6.95	5.56	8.11	3.68	5.60	2.72	4.25	2.14	*2.42	1.80	6.84
		R-Rear Dozer Only Down	*6.95	*6.95	8.11	5.04	5.60	3.65	4.25	2.84	*2.42	2.38	
		R-Outrigger Only Down	*6.95	*6.95	*8.35	8.17	5.88	5.65	4.47	4.28	*2.42	*2.42	
		F-Dozer + R-Outrigger Down	*6.95	*6.95	*8.35	*8.35	*6.60	5.87	*5.42	4.45	*2.42	*2.42	
-1		R-Rear Dozer Only Up	*9.04	5.55	8.08	3.65	5.58	2.70	4.24	2.13	*2.71	1.93	6.50
		R-Rear Dozer Only Down	*9.04	7.99	8.08	5.02	5.58	3.63	4.24	2.83	*2.71	2.55	
		R-Outrigger Only Down	*9.04	*9.04	*8.09	*8.09	5.86	5.62	4.46	4.27	*2.71	*2.71	
		F-Dozer + R-Outrigger Down	*9.04	*9.04	*8.09	*8.09	*6.42	5.84	*5.17	4.44	*2.71	*2.71	
-2		R-Rear Dozer Only Up	*9.41	5.58	*7.37	3.66	5.59	2.71			*3.19	2.17	5.96
		R-Rear Dozer Only Down	*9.41	8.03	*7.37	5.03	5.59	3.64			*3.19	2.88	
		R-Outrigger Only Down	*9.41	*9.41	*7.37	*7.37	*5.83	5.63			*3.19	*3.19	
		F-Dozer + R-Outrigger Down	*9.41	*9.41	*7.37	*7.37	*5.83	*5.83			*3.19	*3.19	
-3		R-Rear Dozer Only Up	*7.62	5.66	*6.01	3.71	*4.43	2.76			*4.03	2.64	5.18
		R-Rear Dozer Only Down	*7.62	*7.62	*6.01	5.08	*4.43	3.69			*4.03	3.52	
		R-Outrigger Only Down	*7.62	*7.62	*6.01	*6.01	*4.43	*4.43			*4.03	*4.03	
		F-Dozer + R-Outrigger Down	*7.62	*7.62	*6.01	*6.01	*4.43	*4.43			*4.03	*4.03	

Feet

Unit : 1,000lb

A(ft) B(ft)	Chassis Frame Attachment	10'		15'		20'		Max. Reach		A(ft)
20	R-Rear Dozer Only Up			*8.43	7.72			*4.65	*4.65	18.18
	R-Rear Dozer Only Down			*8.43	*8.43			*4.65	*4.65	
	R-Outrigger Only Down			*8.43	*8.43			*4.65	*4.65	
	F-Dozer + R-Outrigger Down			*8.43	*8.43			*4.65	*4.65	
15	R-Rear Dozer Only Up			*10.04	7.61	*7.36	4.94	*4.44	*4.44	21.22
	R-Rear Dozer Only Down			*10.04	*10.04	*7.36	6.47	*4.44	*4.44	
	R-Outrigger Only Down			*10.04	*10.04	*7.36	*7.36	*4.44	*4.44	
	F-Dozer + R-Outrigger Down			*10.04	*10.04	*7.36	*7.36	*4.44	*4.44	
10	R-Rear Dozer Only Up	*18.35	13.25	*13.03	7.31	9.42	4.85	*4.50	3.99	22.78
	R-Rear Dozer Only Down	*18.35	*18.35	*13.03	9.74	9.42	6.37	*4.50	*4.50	
	R-Outrigger Only Down	*18.35	*18.35	*13.03	*13.03	9.89	9.5	*4.50	*4.50	
	F-Dozer + R-Outrigger Down	*18.35	*18.35	*13.03	*13.03	*10.39	9.87	*4.50	*4.50	
5	R-Rear Dozer Only Up			14.53	6.98	9.27	4.71	*4.77	3.84	23.17
	R-Rear Dozer Only Down			14.53	9.38	9.27	6.23	*4.77	*4.77	
	R-Outrigger Only Down			*15.10	14.63	9.73	9.34	*4.77	*4.77	
	F-Dozer + R-Outrigger Down			*15.10	*15.10	*11.56	9.71	*4.77	*4.77	
0(Ground)	R-Rear Dozer Only Up	*16.06	11.96	14.25	6.76	9.15	4.61	*5.34	3.97	22.44
	R-Rear Dozer Only Down	*16.06	*16.06	14.25	9.14	9.15	6.13	*5.34	5.25	
	R-Outrigger Only Down	*16.06	*16.06	14.97	14.36	9.62	9.23	*5.34	*5.34	
	F-Dozer + R-Outrigger Down	*16.06	*16.06	*15.98	14.93	*11.74	9.60	*5.34	*5.34	
-5	R-Rear Dozer Only Up	*21.81	11.96	14.19	6.71	9.15	4.61	*6.46	4.48	20.48
	R-Rear Dozer Only Down	*21.81	17.16	14.19	9.09	9.15	6.12	*6.46	5.94	
	R-Outrigger Only Down	*21.81	*21.81	14.90	14.29	9.62	9.22	*6.46	*6.46	
	F-Dozer + R-Outrigger Down	*21.81	*21.81	*15.00	14.86	*9.81	9.59	*6.46	*6.46	
-10	R-Rear Dozer Only Up	*16.38	12.18	*11.15	6.83			*8.84	5.89	16.85
	R-Rear Dozer Only Down	*16.38	*16.38	*11.15	9.22			*8.84	7.87	
	R-Outrigger Only Down	*16.38	*16.38	*11.15	*11.15			*8.84	*8.84	
	F-Dozer + R-Outrigger Down	*16.38	*16.38	*11.15	*11.15			*8.84	*8.84	

1. Ratings are based on SAE J1097
2. Load point is the end of arm.
3. * Rated loads are based on hydraulic capacity.
4. Rated loads do not exceed 87% of hydraulic capacity or 75% of tipping capacity.

: Rating Over Front

: Rating Over Side or 360 degree



Seoul Office :
Doosan Tower 27th FL. 18-12, Euljiro-6 Ga,
Jung-Gu, Seoul, Korea 100-730
Tel : +82-2-3398-8049
Fax : +82-2-3398-8117
www.doosaninfracore.com

Doosan Infracore Europe S.A.

1A, Rue Achille Degrace, 7080 Frameries, Belgium
Tel : +32-65-61-3230 Fax : +32-65-67-7338

Doosan Infracore U.K., Ltd.

Doosan House, Unit 6, 3 Heol Y Gamlas, Parc Nantgarw, Nantgarw,
Cardiff. CF15 7QU, U.K.
Tel : +44-1443-84-2273 Fax : +44-1443-84-1933

Doosan Infracore Europe S.A. Germany

Heinrich-von-Stephan str. 2 40764 Langenfeld, Germany
Tel : +49-2173-2035-210 Fax : +49-2173-2035-219

Doosan Infracore France

ZAC de La Clef Saint Pierre - Buroplus 2 1A Avenue Jean d'Alembert
78990 Elancourt, France
Tel : +33-(0)1-30-16-21-41 Fax : +33-(0)1-30-16-21-44

Doosan Infracore America Corporation

2905 Shawnee Industrial Way, Suwanee, Georgia 30024, U. S. A
Tel : +1-770-831-2200 Fax : +1-770-831-0480

Doosan Infracore China Co., Ltd.

#28, Wuzhishan Road, Eco. & Tech, Development Zone,
Yantai, Shandong, China
Tel : +86-535-638-2000 Fax : +86-535-638-2004

Doosan Infracore Middle East Center (Dubai)

P.O.Box 183127, Al-Serkal Building, Air Port Road, Dubai, U.A.E
Tel : +971-4-295-2781~2 Fax : +971-4-295-2783

Doosan Infracore do Brasil Serviços de Suporte Comercial Ltda.

Alameda Santos 2222 Cj52 CEP 01418.200 São Paulo, SP, Brasil
Tel : +55-11-3061-3227 Fax : +55-11-3061-2731

Doosan Infracore India Pvt.Ltd

Plot No. 34, Door No. 1/61-19, Palwels street, Ravi Colony,
St. Thomas Mount, Chennai-600 016
Tel : +91-44-4222-3900 Fax : +91-44-4222-3905



PBP D140W015 0507

The illustrations do not necessarily show the product in standard version.
All products and equipment are not available in all markets.
Materials and specifications are subject to change without prior notice.